



Bluetooth HD Tower Speaker

User's Guide for Model No. ITB124B v1068-01

For the most up-to-date version of this User's Guide, go to www.iLiveElectronics.com

Safety Instructions & Warnings



WARNING: To reduce the risk of electric shock, do not remove cover (or back). No user-serviceable parts inside. Refer servicing to qualified service personnel.



The exclamation point within an equilateral triangle is intended to alert the user to the presence of important operating and maintenance (servicing) instructions in the literature accompanying the appliance.



The lightning flash with arrowhead symbol, within an equilateral triangle, is intended to alert the user to the presence of uninsulated "dangerous voltage" within the product's enclosure that may be of sufficient magnitude to constitute a risk of electric shock to persons.



This symbol indicates that this product incorporates double insulation between hazardous mains voltage and user accessible parts.

WARNING: DO NOT INGEST BATTERY, CHEMICAL BURN HAZARD.

Important Safety Instructions

- Read these Instructions.
- Keep these Instructions.
- Heed all Warnings.
- Follow all instructions.
- Do not use this apparatus near water.
- Clean only with a dry cloth.
- Do not block any ventilation openings. Install in accordance with the manufacturer's instructions.
- Do not install near any heat sources such as radiators, heat registers, stoves, or other apparatus (including amplifiers) that produce heat.
- Do not defeat the safety purpose of the polarized or grounding - type plug. A polarized plug has two blades with one wider than the other. A grounding type plug has two blades and a third grounding prong. The wide blade or the third prong are provided for your safety. When the provided plug does not fit into your outlet, consult an electrician for replacement of the obsolete outlet.
- Protect the power cord from being walked on or pinched particularly at plugs, convenience receptacles, and the point where they exit from the apparatus.
- Only use attachments/accessories specified by the manufacturer.
- Unplug this apparatus during lightning storms or when unused for long periods of time.
- Refer all servicing to qualified service personnel. Servicing is required when the apparatus has been damaged in any way, such as power-supply cord or plug is damaged, liquid has been spilled or objects have fallen into the apparatus, the apparatus has been exposed to rain or moisture, does not operate normally, or has been dropped.
- Use only with a cart, stand, tripod, bracket, or table specified by the manufacturer, or sold with the apparatus. When a cart is used, use caution when moving the cart/apparatus combination to avoid injury from tip-over.



FCC Warnings

Warning: Changes or modifications to this unit not expressly approved by the party responsible for compliance could void the user's authority to operate the equipment.

NOTE: This equipment has been tested and found to comply with the limits for a Class B digital device, pursuant to Part 15 of the FCC Rules. These limits are designed to provide reasonable protection against harmful interference in a residential installation. This equipment generates, uses, and can radiate radio frequency energy and, if not installed and used in accordance with the instructions, may cause harmful interference to radio communications. However, there is no guarantee that interference will not occur in a particular installation. If this equipment does cause harmful interference to radio or television reception, which can be determined by turning the equipment off and on, the user is encouraged to try to correct the interference by one or more of the following measures:

- Reorient or relocate the receiving antenna.
- Increase the separation between the equipment and receiver.
- Connect the equipment into an outlet on a circuit different from that to which the receiver is connected.
- Consult the dealer or an experienced radio/TV technician for help.

Safety Instructions & Warnings

Additional Warnings and Precautions

- **CAUTION:** TO PREVENT ELECTRIC SHOCK, MATCH WIDE BLADE OF PLUG TO WIDE SLOT, FULLY INSERT.
AVIS: AFIN DE PRÉVENIR LES CHOC ÉLECTRIQUES, FAITES CORRESPONDRE LA FICHE BLANCHE DE LA PRISE À LA FENTE LARGE, INSÉREZ TOTALEMENT.
- **WARNING:** To reduce the risk of fire or electric shock, do not expose this apparatus to rain, moisture, dripping, or splashing.
AVIS: Pour réduire le risque d'incendie ou de choc électrique, n'exposez pas cet appareil à la pluie ou l'humidité ou aux éclaboussures.
- **CAUTION:** Use of controls or adjustments or performance of procedures other than those specified may result in hazardous radiation exposure.
AVIS: L'utilisation de commande ou l'exécution de procédures autres que celles spécifiées ici peuvent aboutir à une exposition à des radiations dangereuses.
- **WARNING:** Changes or modifications to this unit not expressly approved by the party responsible for compliance could void the user's authority to operate the equipment.
AVIS: Des changements ou des modifications sur ce produit non expressément approuvés par la partie responsable de la conformité peut annuler le droit de l'utilisateur d'utiliser cet équipement.
- **WARNING:** Do not place this unit directly onto furniture surfaces with any type of soft, porous, or sensitive finish. As with any rubber compound made with oils, the feet could cause marks or staining where the feet reside. We recommend using a protective barrier such as a cloth or a piece of glass between the unit and the surface to reduce the risk of damage and/or staining.
AVIS: Ne placez pas cette unité directement sur des surfaces de meubles dont la finition serait douce, poreuse ou sensible. Car, comme tout composé caoutchouc a base d'huiles, les pieds pourraient laisser des traces ou des taches à l'endroit où ils sont posés. Nous recommandons d'utiliser une protection comme un linge ou un morceau de verre entre l'unité et la surface pour réduire le risque de dégât et/ou de tache.
- **WARNING:** Use of this unit near fluorescent lighting may cause interference regarding use of the remote. If the unit is displaying erratic behavior move away from any fluorescent lighting, as it may be the cause.
AVIS: L'utilisation de cette unité en présence de lumières fluorescentes peut causer des interférences lors de l'utilisation de la télécommande. En cas de dysfonctionnement, éteignez les sources de lumière fluorescentes, car celles-ci pourraient en être la cause.
- **CAUTION:** Danger of explosion if battery is incorrectly replaced. Replace only with the same or equivalent type.
AVIS: Un danger d'explosion est présent lorsque les piles sont remplacées de manière incorrecte. Remplacez seulement les piles par des piles de type équivalent.
- **WARNING:** There is a danger of explosion if you attempt to charge standard Alkaline batteries in the unit. Only use rechargeable NiMH batteries.
AVIS: Charger des piles alcalines dans l'unité peut causer une explosion. Utilisez seulement des piles rechargeables NiMH.
- **WARNING:** The remote control's button cell battery contains mercury. Do not put in the trash, instead recycle or dispose of as hazardous waste.
AVIS: Les piles boutons de la télécommande contiennent du mercure. Ne les jetez pas à la corbeille, recyclez-les ou disposez-les comme des déchets dangereux.
- **WARNING:** Lithium batteries, like all rechargeable batteries, are recyclable and should be recycled or disposed of in normal household waste. Contact your local government for disposal or recycling practices in your area. They should never be incinerated since they might explode.
AVIS: Les piles Lithium ion, comme toutes les autres piles rechargeables, sont recyclables et doivent être étiquetées avec vos déchets ménagers. Contactez votre municipalité pour obtenir des conseils sur les moyens de disposition et de recyclage dans votre région. N'incinerez pas vos piles, car celles-ci peuvent exploser.
- **WARNING:** Shock hazard - Do Not Open.
AVIS: Risque de choc électrique - ne pas ouvrir
- Caution and marking information is located at the rear or bottom of the apparatus.
Attention et de marquage des informations est situé sur le panneau arrière ou inférieur de l'unité.
- Objects filled with liquids, such as vases, shall not be placed on the apparatus.
Objets remplis de liquides, comme des vases, ne doivent pas être placés sur l'appareil.
- Mains plug is used as disconnect device and it should remain readily operable during intended use. In order to disconnect the apparatus from the mains completely, the mains plug should be disconnected from the mains socket outlet completely.
La prise du secteur est utilisé pour déconnecter le système. La prise du secteur ne doit pas être obstruée ou doit être facilement accessible pendant son utilisation. Pour être complètement déconnecté de l'alimentation d'entrée, la prise doit être débranchée du secteur.
- Battery shall not be exposed to excessive heat such as sunshine, fire or the like.
Les piles ne doivent pas être exposées à de forte chaleur, tel qu'à la lumière du soleil, au feu ou autres choses de semblable.
- This product is supplied with a coin/button cell battery. If the coin/button cell battery is swallowed, it can cause severe internal burns and can lead to death.
Ce produit est livré avec une pile pièce / touche. Si la pile pièce / bouton est avalé, il peut causer des brûlures internes graves et peut conduire à la mort.
- Keep new and used batteries away from children. If the battery compartment does not close securely, stop using the product and keep it away from children.
Gardez les piles neuves et d'occasion à partir des enfants. Si le compartiment de la batterie ne pas fermer correctement, cesser d'utiliser le produit et garder loin des enfants.
- If you think batteries might have been swallowed or placed inside any part of the body, seek immediate medical attention. Si vous pensez que les batteries peuvent avoir été avalé ou placé à l'intérieur d'une partie du corps, consulter immédiatement un médecin.
- Do not mix old and new batteries.
Ne pas mélanger vieilles et nouvelles batteries.
- Completely replace all old batteries with new ones.
Remplacer complètement toutes les piles par des neuves.
- Do not mix alkaline, standard (carbon-zinc), or rechargeable (ni-cad, ni-mh, etc) batteries.
Ne mélangez pas des piles alcalines, standard (carbone-zinc) ou rechargeables (Ni-Cd, Ni-MH, etc) batteries.
- Batteries should be recycled or disposed of as per state and local guidelines.
Piles doivent être recyclées ou éliminées selon les directives étatiques et locales.

Table of Contents

Unboxing Your HD Tower Speaker	5
Features & Specifications	
Includes	
Setup	5
Power	
Remote Battery	
Attaching the Stand	
Orientation	6-7
Speaker Controls & Inputs	
Remote Layout	
Audio Inputs	8-9
Using the Stereo RCA Inputs	
Using the Line In	
Bluetooth & Radio	10
Pairing a Bluetooth Device for the First Time	
Playing Audio Wirelessly	
Tuning the FM Radio	
Automatically Programming Memory Presets	
Manually Programming Memory Presets	
Clock	11
Setting the Clock	
Company Information	12
Contact Information	
International Support	
Green Initiative	
Warranty	

Unboxing Your HD Tower Speaker

Features & Specifications

- Supports Bluetooth v2.1
- Wireless range: 33 feet
- Pairing button
- Built-in 4 x 3" high power speakers
- LED light effects
- Digital FM radio (PLL)
- Station memory presets (20 FM)
- 3.5mm audio input
- RCA stereo audio inputs
- Built-in FM wire antenna
- Negative LCD display with white backlight
- EQ presets
- Digital volume control
- Bass controls
- Treble controls
- Digital clock
- Remote
- Supports Enhanced Data Rate (EDR)
- Supports profile A2DP (Advanced Audio Distribution Profile)
- DC power input: requires an AC/DC power adapter (included)

Features & Specifications

- Remote control:
 - requires a CR2025 battery (pre-installed)
- RCA stereo audio cable
- AC/DC power adaptor
- Wooden stand and mounting hardware

Setup

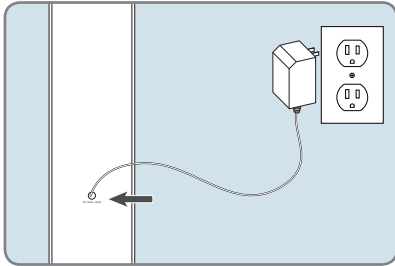

Power

Plug the small end of the power cord into the DC Input on the back of the speaker, and the large plug into a standard wall outlet.

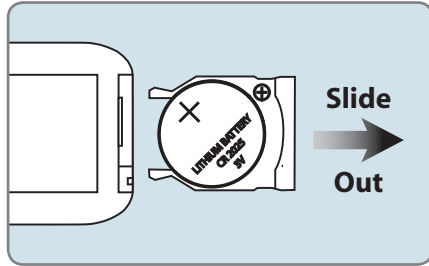

Remote Battery

Requires a CR2025 battery (pre-installed).

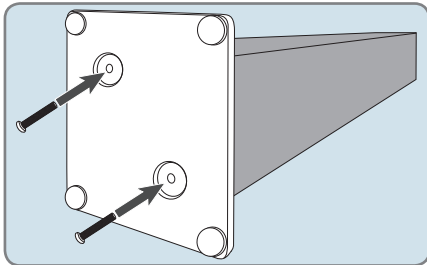

Attaching the Stand

Align the holes in the bottom of the unit to the holes in the base. Use a philips-head screwdriver to tighten or remove the screws. Using a power drill could damage the TV stand.

Orientation

Speaker Controls & Inputs

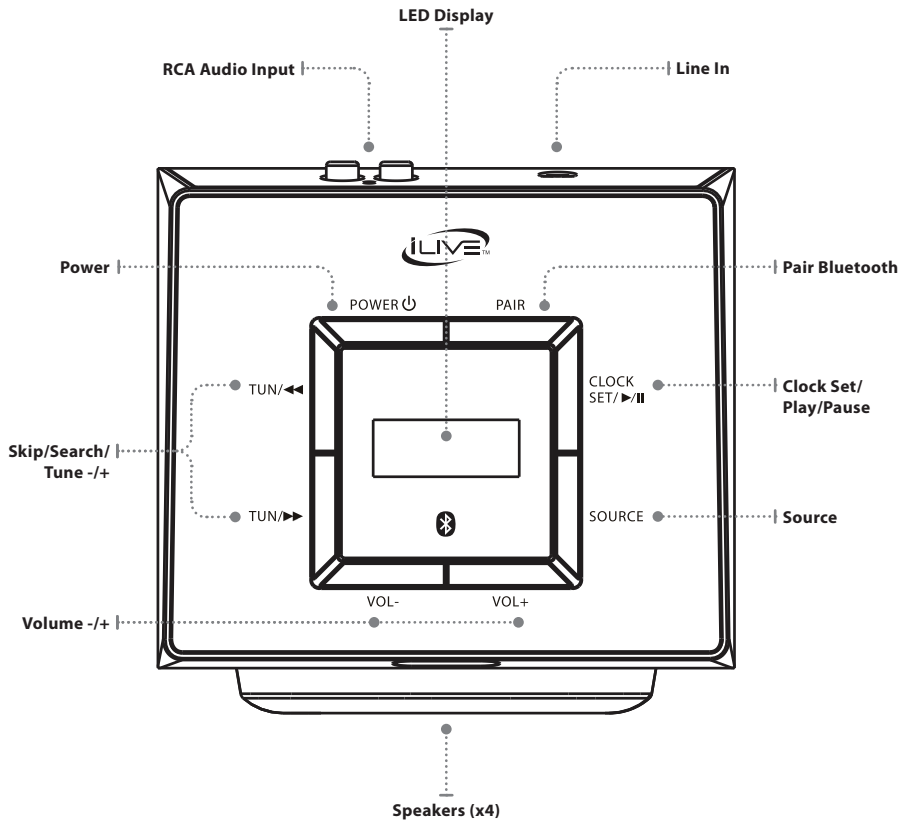

Remote Layout

Power

Press to turn the unit on or off.

Source

Press to cycle between Aux, Bluetooth, Line in, and FM radio.

Tune +/- Skip

In FM mode, press to adjust frequency of the FM radio.

In Bluetooth mode, press to skip a track.

Play/Pause

Press to play or pause a track in Bluetooth mode.

Memory

Press to save a radio station to memory.

EQ

Press to cycle through equalizer settings.

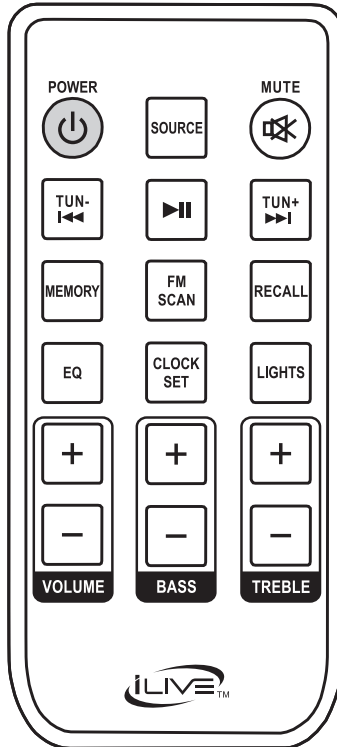

Mute

Press to mute the volume.

FM Scan

Press to begin scanning and saving FM radio frequencies.

Recall

Press to cycle through saved radio stations.

Clock Set

With the unit off, press to begin setting the clock, then use the **Tun +/-** buttons to set the time.

Lights

Press to turn the speaker lights on or off.

Volume

Press to adjust the volume.

Bass

Press to adjust the bass up or down.

Treble

Press to adjust the treble up or down.

Audio Inputs

Using the Stereo RCA Inputs

When connecting two products using an RCA Cable, match the colored ports with the same colored connection.

1. Connect the RCA Cable to the RCA Stereo Inputs located on the back of the unit, and to the audio outputs on the television.
2. Press the **Power** button to power on the unit.
3. Press the **Source** button repeatedly to enter **AUX Mode**.
4. Audio played through the television will now be heard through the speakers.

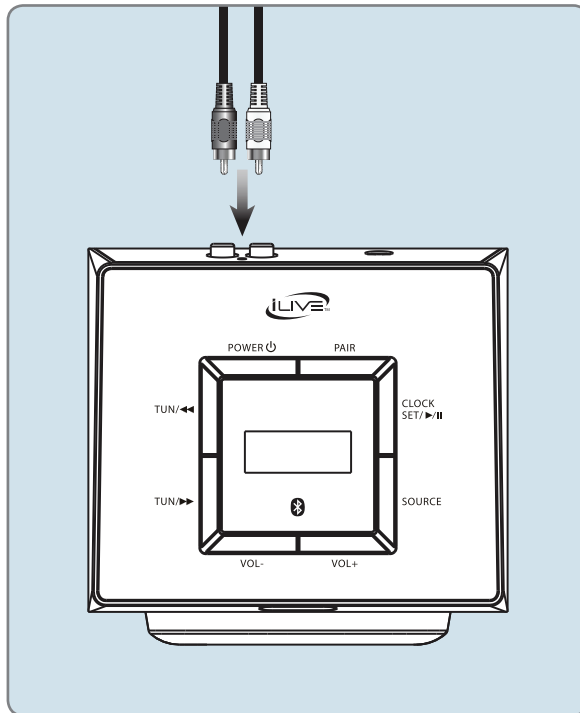

Using the Line In

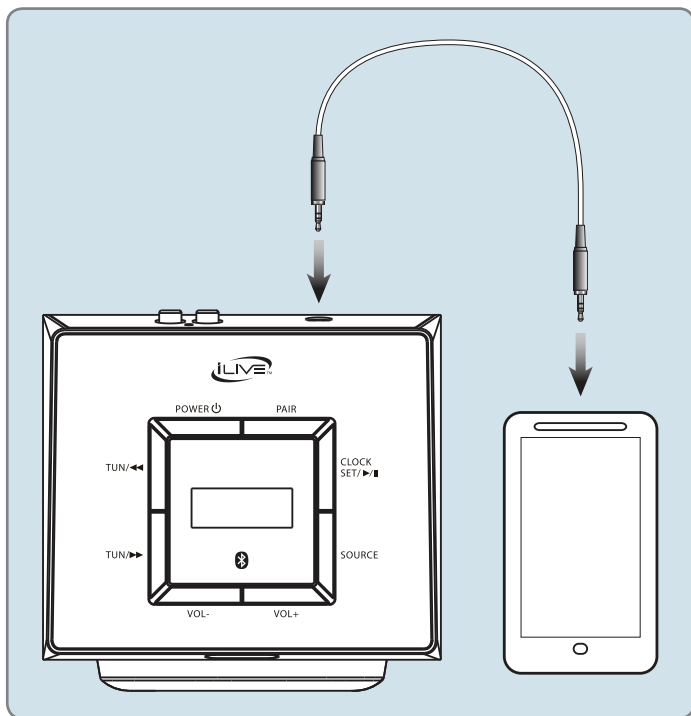

3.5 mm audio input cable not included.

1. Plug one end of a 3.5 mm audio input cable into the **Line In** on the unit, and plug the other end of the cable into the audio output/headphone output on an MP3 Player or other audio source.
2. Press the **Power** button to power the unit on.
3. Press the **Source** button repeatedly to enter **Line In Mode**.
4. Audio played through the connected device will now be heard through the speakers.



Bluetooth & Radio

Pairing a Bluetooth Device for the First Time

1. Power on the unit by pressing the **Power** button.
2. Press the **Source** button on the remote to switch to Bluetooth Mode, indicated by a slowly flashing  indicator on the display.
3. Press the **Pair** button on the top of the unit.
The pairing indicator will flash quickly. When pairing, remain within 3 feet of the unit.
4. Using the native controls on your Bluetooth device, select the **ITB124** in your Bluetooth settings to pair. If your device requests a password, enter the default password **0 0 0 0**.
Refer to the user's manual for your specific device for instructions on pairing and connecting Bluetooth devices.
5. When successfully paired and connected, a beep will issue from the unit and the  indicator will stop flashing and become solid.

After initial pairing, the unit will stay paired unless unpaired manually by the user or erased due to a reset of the device. If your device should become unpaired or you find it is unable to connect, repeat the above steps.

Playing Audio Wirelessly

1. After pairing to a Bluetooth device, use the controls on the remote, the unit, or the native controls on the connected Bluetooth Device to play, pause or skip a selected track.
2. Audio played through the connected Bluetooth device will now be heard through the speakers.

Tuning the FM Radio

1. Press the **Power** button to turn the unit on.
2. Press the **Source** button to switch the unit to FM Radio Mode.
3. Press the **Tun-/+** buttons on the unit or the remote to scan for the next available station.
4. Press and hold the **Tun-/+** buttons to search for the next available station.

Automatically Programming Memory Presets

1. Press the **Source** button to enter FM Radio Mode.
2. Press the **FM Scan** button on the remote.
3. The speaker will scan for all available stations, and store them.
4. Press the **Recall** button on the remote repeatedly to cycle through your stored stations.

Manually Programming Memory Presets

1. Press the **Source** button to enter FM Radio Mode and tune to the desired frequency using the **Tun -/+** buttons on the remote.
2. Press anywathe **Memory** button on the remote, then press the **Tun -/+** buttons to select a Memory Preset (1 to 20). Press the **Memory** button again to save the radio frequency to that preset.
3. Press the **Recall** button on the remote repeatedly to cycle through your stored stations.

Clock

Setting the Clock

1. With the unit powered off, press and hold the **Clock Set** button (or press the Clock Set button on the remote).
2. The hour will begin to flash.
3. Press the **Tun +/-** buttons to adjust the hour.
4. Press the **Clock Set** button.
5. The minute will begin to flash.
6. Press the **Tun +/-** buttons to adjust the minute.
7. Press the **Clock Set** button again to finish setting the time.

Company Information

Contact Information

Website: www.gpx.com

Email Support: prodinfo@dpiinc.com

Email Parts: partsinfo@dpiinc.com

Phone Support: 1-888-999-4215

Warranty

For Warranty Information and the most up-to-date version of this User's Guide, go to: www.gpx.com

International Support

To download this User's Guide in English, Spanish, and French, or to get answers to frequently asked questions, visit the support section at: www.gpx.com

Para descargar este Manual del Usuario en inglés, español y francés, o para obtener respuestas a preguntas frecuentes, visite la sección de apoyo en: www.gpx.com

Pour télécharger ce guide de l'utilisateur en anglais, espagnol ou français, ou pour obtenir des réponses à des questions fréquemment posées, consultez la rubrique d'assistance sur: www.gpx.com

Green Initiative

Our Environmental Commitment to "Protect for Today and Sustain for Tomorrow". On a continual basis DPI, Inc. is making efforts to sustain the environment and improve the recyclability of its products and packaging.

Focusing on "protecting for today and sustaining for tomorrow" DPI, Inc. has committed to reducing packaging size, increasing the usage of recyclable plastics, and ensuring that packaging and manuals are made with up to 85% recycled material. In addition to material consideration, DPI, Inc. has also focused on the finer details that positively impact the environment such as employing the usage of soy-based inks.

DPI, Inc. also ensures that the factories that produce the company's wide variety of consumer electronics adhere to environmentally friendly air and water restrictions. This is yet another example that every step of the way DPI, Inc. is making efforts to lessen any impact on the environment.

In 2011 DPI, Inc. also began conversations with Energy Star in order to ensure that the consumer electronics being produced meet high standards of energy efficiency. The ultimate goal is keeping energy costs for consumers low while providing quality, feature-rich products.



Copyright © 2014 Digital Products International (DPI, Inc.) All other trademarks appearing herein are the property of their respective owners. Specifications are subject to change without notice.