

Truly Wire Free Earbuds

User's Guide for Model IAEBTW59 v2253-02

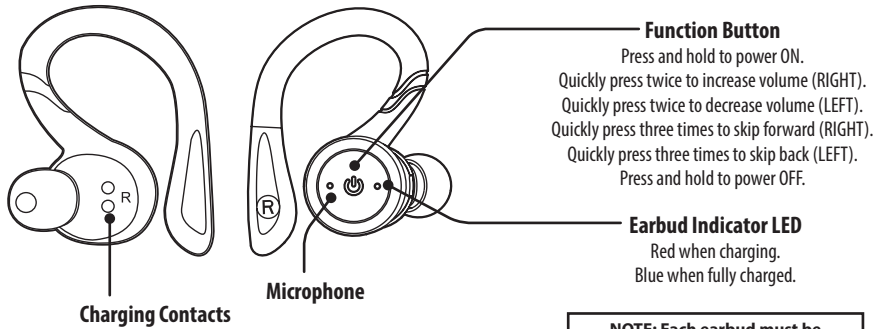

NOTE: Each earbud must be powered on separately. Once they are linked, powering off one earbud will power off both.

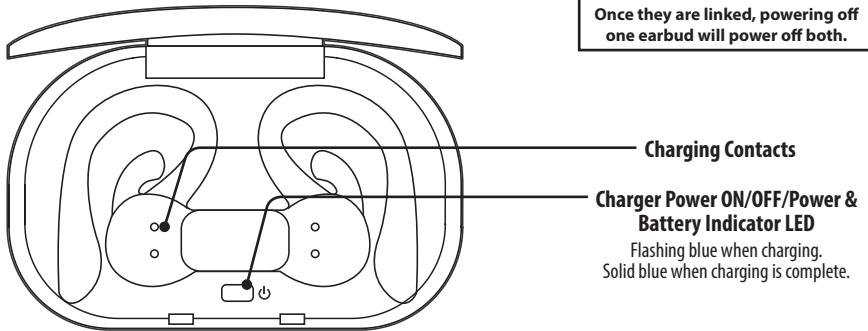

Charging the Earbuds

1. Open the cover and place the earbuds on the charging contacts. Be sure to match the left and right earbuds with the correct docking station in the case.
2. Press the **Power** button on the case to power it ON and charge the earbuds.
3. When charging, the indicator LEDs on the earbuds will turn red. When charging is complete, the indicators will turn blue.

Charging the Case

Using a **Micro-USB to USB** cable, connect to the USB port of a powered on computer or USB power adaptor (not included) to charge the case.

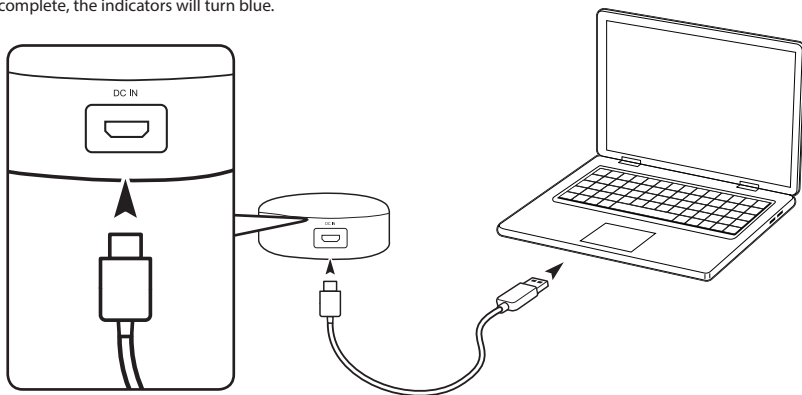

Changing Earhooks

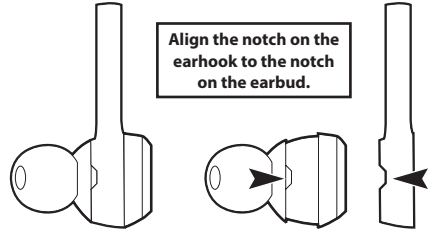
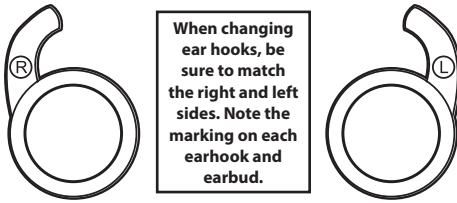

Linking Earbuds

To link the earbuds:

- Press and hold the **Function** button on **both earbuds** until they start blinking blue and red, and they will automatically connect to each other.
- When successfully linked, the LED indicator on the **left earbud** will begin flashing blue and red, while the other very slowly flashes blue. A voice prompt will also announce when the earbuds have linked.

Pairing Bluetooth

Note: When using as a linked pair, the left earbud is the main unit. Use the left earbud Function button to control both. You can power on a single earbud to use as a single unit if you wish.

1. With the earbuds linked, you can now connect to your Bluetooth device. The **LED indicator** on the left earbud will continue flashing blue and red, indicating it is ready to pair to a Bluetooth device.
2. On your Bluetooth device, access Bluetooth Settings and search for nearby devices. Select **IAEBTW59** when it is discovered. When successfully connected to your Bluetooth device, the LED indicator on both of the earbuds will blink blue once every 10 seconds and a voice prompt will announce the Bluetooth connection.
3. Audio played through the connected Bluetooth device will now be heard through both earbuds. Use the controls on the connected device to play audio and adjust volume.

PLEASE NOTE: Due to the nature of truly wireless earbuds, you may experience slight interruptions with your audio in areas with multiple 2.4Ghz bands or in high wireless traffic areas.

Speakerphone

- To accept or end a phone call, press the **Function** button.
- You can also use the controls on the connected phone to handle phone functions.

Charging Case & Auto-On Feature

While the case power is ON:

- Placing the earbuds in the charging case will automatically power them off and begin charging.
- Removing the earbuds from the case will automatically power them on, link them, and connect to the last used Bluetooth device (earbuds must have been linked and connected to a Bluetooth device already).

Customer Support

Customer Service: 1-888-999-4215 | **Email Support:** prodinfo@dpiinc.com | **Email Parts:** partsinfo@dpiinc.com

For Warranty Information and the most up-to-date version of this User's Guide, go to www.iLiveElectronics.com

To download this User's Guide in English, Spanish, or French, or to get answers to frequently asked questions, visit the support section at: www.iLiveElectronics.com

Para descargar este Manual del Usuario en inglés, español y francés, o para obtener respuestas a preguntas frecuentes, visite la sección de apoyo en: www.iLiveElectronics.com

Pour télécharger ce guide de l'utilisateur en anglais, espagnol ou français, ou pour obtenir des réponses à des questions fréquemment posées, consultez la rubrique d'assistance sur: www.iLiveElectronics.com

Copyright © 2019 Digital Products International (DPI, Inc.) All other trademarks appearing herein are the property of their respective owners. Specifications are subject to change without notice.

FCC Warnings

WARNING: Changes or modifications to this unit not expressly approved by the party responsible for compliance could void the user's authority to operate the equipment.

NOTE: This equipment has been tested and found to comply with the limits for a Class B digital device, pursuant to Part 15 of the FCC Rules. These limits are designed to provide reasonable protection against harmful interference in a residential installation. This equipment generates, uses, and can radiate radio frequency energy and, if not installed and used in accordance with the instructions, may cause harmful interference to radio communications. However, there is no guarantee that interference will not occur in a particular installation. If this equipment does cause harmful interference to radio or television reception, which can be determined by turning the equipment off and on, the user is encouraged to try to correct the interference by one or more of the following measures:

- Reorient or relocate the receiving antenna.
- Increase the separation between the equipment and receiver.
- Connect the equipment into an outlet on a circuit different from that to which the receiver is connected.
- Consult the dealer or an experienced radio/TV technician for help.

Additional Warnings

- **WARNING:** To prevent fire or shock hazards, do not expose this unit to rain or moisture.
- **WARNING :** Where the mains plug or appliance coupler is used as the disconnect device, such disconnect device shall remain readily operable.
- Lithium batteries, like all rechargeable batteries, are recyclable and should be recycled or disposed of according to state and local guidelines. They should never be disposed of in normal household waste, and they should never be incinerated, as they might explode. Contact your local government for disposal or recycling practices in your area.
- This product meets and complies with all Federal regulations.
- **To avoid hearing damage,** make sure that the volume on your music player is turned down before connecting your headphones. After placing headphones in/on your ears, gradually turn up the volume until you reach a comfortable listening level.



WARNING : This product can expose you to chemicals including lead, which is known to the State of California to cause cancer and birth defects or other reproductive harm. For more information go to www.P65Warnings.ca.gov.

This product meets and complies with all Federal regulations.