



**EAGLE<sup>®</sup> PRO**

**6-ROTOR DRONE WITH WIFI CAMERA**

*User's Guide for Model DRW676 v1523-01*

# Warnings & Precautions

---

## Important Safety Instructions

- Read and follow all instructions.
- Keep these instructions for future reference.
- Heed all Warnings.
- Intended for children ages 14 and higher. Adult supervision is required.
- Only use attachments/accessories specified by the manufacturer.
- Before flying, always check the body, rotors, and battery for any damage or obstructions.
- Battery should be free from cracks or swelling.
- Keep the rotors clear of any obstructions and body parts to avoid potential damage and injury.
- Manufacturer and dealer assume no liability for accidental damages from improper use or installation of parts, or from damage incurred from worn or broken parts.
- Pilots are responsible for their actions and any damage caused from improper use.
- Pilots should keep the craft in sight at all times during flight. If you lose sight of the craft at any time, power down and cease flight immediately.
- Only fly in large, open areas that are free from obstacles or potential hazards, such as trees, power lines, ceiling fans, and the like.
- Flying over bodies of water is not recommended.
- Flying at night is not recommended.
- Never try to retrieve the craft from areas you cannot safely reach, such as rooftops or trees.
- Never launch the craft from your hand.
- Never leave the craft unattended while it is powered on or while the battery is charging.

## FCC Warnings

Warning: Changes or modifications to this unit not expressly approved by the party responsible for compliance could void the user's authority to operate the equipment.

NOTE: This equipment has been tested and found to comply with the limits for a Class B digital device, pursuant to Part 15 of the FCC Rules. These limits are designed to provide reasonable protection against harmful interference in a residential installation. This equipment generates, uses, and can radiate radio frequency energy and, if not installed and used in accordance with the instructions, may cause harmful interference to radio communications. However, there is no guarantee that interference will not occur in a particular installation. If this equipment does cause harmful interference to radio or television reception, which can be determined by turning the equipment off and on, the user is encouraged to try to correct the interference by one or more of the following measures:

- Reorient or relocate the receiving antenna.

- Increase the separation between the equipment and receiver.
- Connect the equipment into an outlet on a circuit different from that to which the receiver is connected.
- Consult the dealer or an experienced radio/TV technician for help.

## Additional Warnings & Precautions

- **WARNING:** To reduce the risk of fire or electric shock, do not expose this apparatus to rain, moisture, dripping, or splashing.
- **CAUTION:** Use of controls or adjustments or performance of procedures other than those specified may result in personal injury.
- **WARNING:** Changes or modifications to this unit not expressly approved by the party responsible for compliance could void the user's authority to operate the equipment.
- **CAUTION:** Danger of explosion if battery is incorrectly replaced. Replace only with the same or equivalent type.
- Lithium batteries, like all rechargeable batteries, are recyclable and should be recycled or disposed of according to state and local guidelines. They should never be disposed of in normal household waste, and they should never be incinerated, as they might explode. Contact your local government for disposal or recycling practices in your area.
- **WARNING:** Shock hazard - Do Not Open.
- Battery shall not be exposed to excessive heat such as sunshine, fire, or the like.
- Keep new and used batteries away from children. If the battery compartment does not close securely, stop using the product and keep it away from children.
- If you think batteries might have been swallowed or placed inside any part of the body, seek immediate medical attention.
- Do not mix old and new batteries.
- Completely replace all old batteries with new ones.
- Do not mix alkaline, standard (carbon-zinc), or rechargeable (ni-cad, ni-mh, etc) batteries.
- Batteries should be recycled or disposed of as per state and local guidelines.
- **WARNING:** This product may contain chemicals known to the State of California to cause birth defects, or other reproductive harm (California Prop 65). Wash hands after handling.
- This product meets and complies with all Federal regulations.

# Table of Contents

---

## **FAA Registration–4**

- Which UAS Must Be Registered?
- Who Can Register?
- What Do You Need to Register?
- Additional Info

## **Orientation–5**

- Includes
- Overview
- Remote Control

## **Batteries & Charging–7**

- Battery Info
- Remote Control Battery Installation
- Battery Charging Procedure

## **Pre-Flight Calibration –10**

- Hexacopter/Remote Link

## **Trim Adjustment–12**

- Setting Trim & Countering Drift

## **Flying Tips & Features–14**

- Tips for Safe Operation
- Speed Setting
- Auto-Return
- Headless Mode
- Flips & Tricks

## **WiFi Mode –16**

- SkyRider Drones App
- WiFi Flight
- Start Screen
- Flight Screen
- Intuitive Mode
- Attaching the Smartphone Cradle

## **Factory Reset–20**

- Reset Procedure

## **Repair–22**

- Parts Replacement
- Rotor Replacement

## **Troubleshooting–23**

## **Company Information–24**

- Contact Information
- International Support
- Warranty

# FAA Registration

---

As of December 21, 2015, the U.S. Federal Aviation Administration (FAA) has mandated that all Unmanned Aircraft Systems (UAS) of a certain weight must be registered with the FAA before flying outdoors. This includes aircraft commonly referred to as drones, quadcopters, Unmanned Aerial Vehicles (UAV), and the like. Owners not in compliance are subject to civil and criminal penalties.

The Online Registration fee is \$5, but will be credited back to your account if the registration is completed within the first 30 days of ownership. Once completed, the registration is valid for 3 years.

## Which UAS Must Be Registered?

The Online Registration requirement applies to all UAS that weigh between 0.55 lbs (250g) and 55 lbs (25kg). **The SkyRider Eagle Pro meets this requirement, and must be registered, and your FAA Registration ID Number must be permanently affixed to the craft.**

Aircraft that weigh more than 55 lbs have a different set of criteria for registration.

## Who Can Register?

- Anyone 13 years of age or older. A person who does not meet this age requirement must have their UAS registered by someone 13 years of age or older.
- A US citizen or legal permanent resident.

## What Do You Need to Register?

When registering online, you will need:

- A valid email address
- A Credit or Debit Card
- A physical and mailing address (if different from physical address)

## Additional Info

For more detailed information on the FAA and the registration process, visit the web links listed below.

- **FAA Home Page** - <http://www.faa.gov/>
- **UAS Registration Page** - <http://www.faa.gov/uas/registration/>
- **UAS Registration FAQs** - <http://www.faa.gov/uas/registration/faqs/>

# Orientation

---

## Includes

- Remote control: requires 4 AA batteries (not included)
- 2 rechargeable lithium polymer batteries
- USB cable for battery recharge
- 6 replacement rotors
- Screwdriver
- Detachable smartphone cradle

## Overview

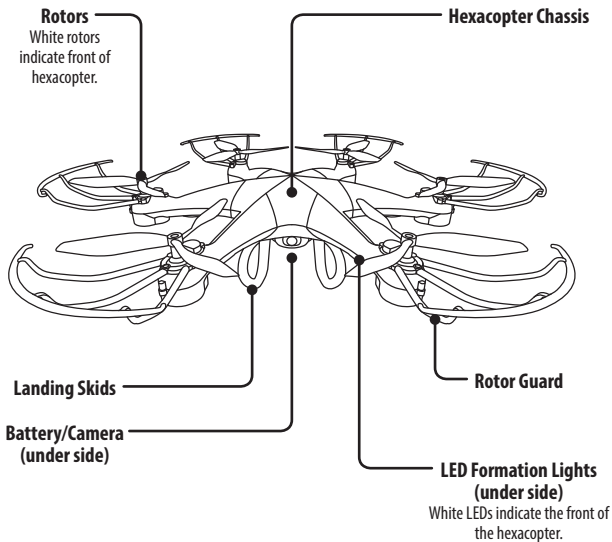

# Orientation

---

## Remote Control

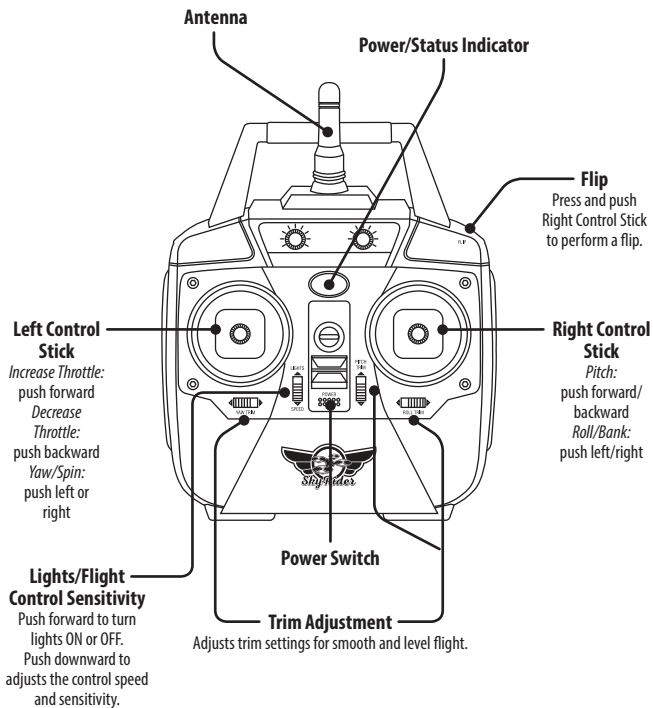

# Batteries & Charging

---

## Battery Info

BATTERY TYPE	SPECIFICATION	DURATION	CHARGE TIME
Hexacopter Li-Po Battery	3.7V/750mAh	6 to 8 minutes flight time	Approx. 120 minutes
Remote AA Batteries	1.5V	Approx. 18 hours	Non-rechargeable

## Remote Control Battery Installation

Use included screwdriver

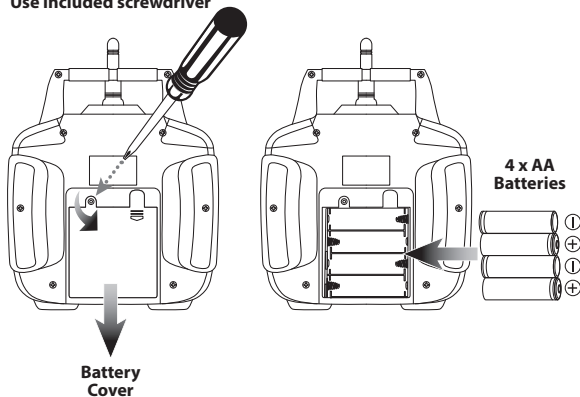

# Batteries & Charging

---

## Battery Charging Procedure

The hexacopter's lithium-polymer battery must be charged before the unit can be flown. Before charging, be sure the hexacopter and remote control are powered off. Failure to do so may result in injury.

### Step 1

Make sure the hexacopter is powered OFF, then open the battery cover by gently pulling towards the rear of the craft.

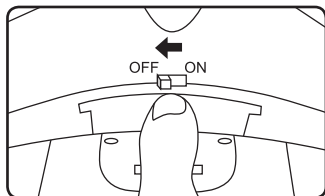

### Step 2

Disconnect the battery and hexacopter power plugs. Slide the battery out of its bay for easier access or replacement.

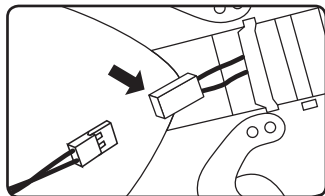

### Step 3

Attach the plug on the battery to the corresponding plug on the USB charging cable (included).

**Be sure to match the plugs correctly or damage may occur.**

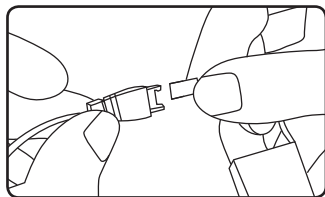

---

## Step 4

Connect the USB charging cable to the USB port of a powered ON computer.

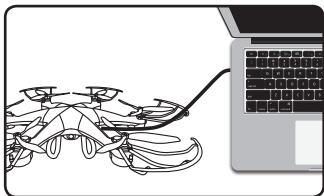

While charging, the red light in the USB charging cable will be ON.

When charging is complete, the red light in the USB charging cable will be OFF.

LIGHT	STATUS
Red Light ON	Charging
Red Light OFF	Ready

## Step 5

When charging is complete, reconnect the power plugs, and close the battery cover.

**Be sure to match the plugs correctly or damage may occur.**

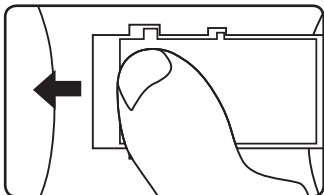

# Pre-Flight Calibration

---

## Hexacopter/Remote Link

Before flying, the hexacopter and the remote must be linked together, and the gyroscopes on the hexacopter must be allowed to calibrate to ensure smooth and level flight.

Begin with the hexacopter and remote powered off.

### Step 1

Place the hexacopter on a flat, level surface before you begin.

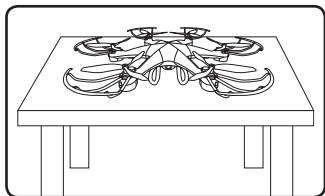

### Step 2

Power the remote control ON. The light on the remote will blink as it searches for the signal from the hexacopter.

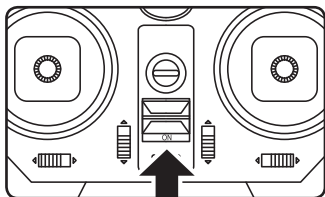

### Step 3

Power the hexacopter ON. The LED formation lights will blink in unison as the hexacopter searches for a signal from the remote. An audible chime will sound when the remote and the hexacopter have linked with each other.

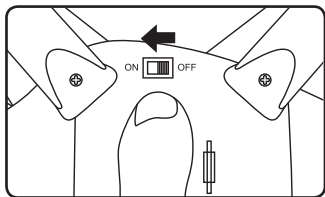

---

## Step 4

Push the Left Control Stick directly forward, wait for a chime to sound, then pull the stick directly backward, and wait for a second chime.

**When this last chime has sounded, the hexacopter is calibrated and ready to fly.**

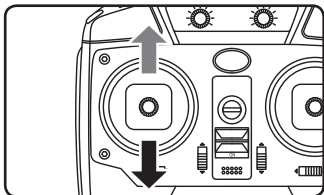

## Step 5

Attempt a stable hover, low to the ground or surface you started on. If you notice a tendency to drift, you may need to adjust the trim controls to fine tune the handling (see next section).

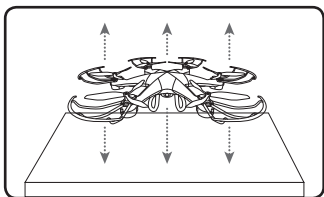

# Trim Adjustment

---

## Setting Trim & Countering Drift

Even after the hexacopter is calibrated, it may show a tendency to drift while airborne. Adjusting the trim will help counter this effect and allow you to better control the craft. To avoid potential damage, adjust the trim while in a stable hover, and do not make any sudden movements with the flight controls. Adjust one trim setting at a time to avoid confusion.

**Remember, the white propeller blades/LEDs indicate the front of the hexacopter.**

Note that, while adjusting the trim will help with drift, it will not eliminate it entirely. Turbulence and other environmental factors may still act on the hexacopter to influence its direction and flight.

### DRIFT TYPE

Hexacopter yaws/spins in place.

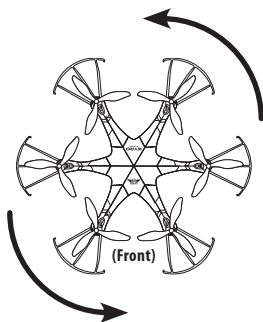

### SOLUTION

Use Yaw Trim buttons under the Left Control Stick.

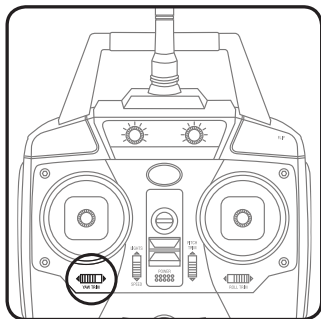

---

Hexacopter pitches/angles forward or backward.

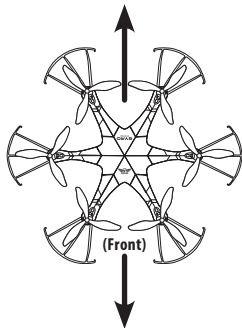

Use Pitch Trim buttons left of the Right Control Stick.

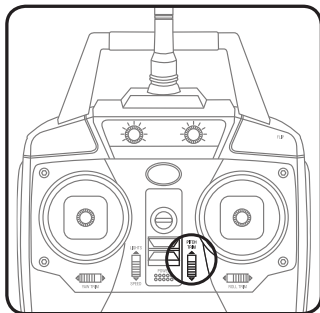

Hexacopter rolls/banks left or right.

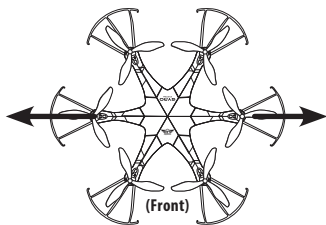

Use Roll Trim buttons under the Right Control Stick.

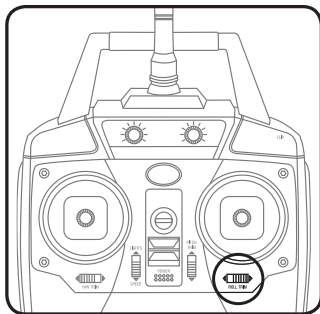

# Flying Tips & Features

---

## Tips for Safe Operation

- Only fly in large, open spaces, such as a field or a very large indoor area, free of obstacles like power lines, trees, ceiling fans, etc.
- When flying indoors, avoid walls and ceilings, as the hexacopter will be drawn towards them if closer than 2 to 3 feet.
- Stand behind the hexacopter when first taking off, so that you and the hexacopter are facing the same “forward” direction. This will make it easier to know which direction the unit is flying. Also, remember that the white propellers and LED lights indicate the front of the hexacopter.
- Practice basic flight operations like take off, hovering, and landing.
- Flying inside, at low speed and low to the ground will reduce the chance of turbulence that can negatively affect the stable flight of the hexacopter.
- Novice pilots should move the controls slowly and deliberately, using one control at a time, to get used to the hexacopter’s flying characteristics. Next try combining the pitch and roll controls (forward/backward and left/right on the Right Control Stick) to fly the hexacopter similar to the way an airplane flies. After mastering this, try the yaw controls (left/right on the left thumbstick) to spin the hexacopter in place and perform more complex maneuvers.
- When you crash, throttle down the engines IMMEDIATELY to reduce the chance of permanent damage to the hexacopter and other objects.
- If anything obstructs the propellers for any reason, throttle down IMMEDIATELY and safely clear the obstruction. Check for possible damage before flying again.

## Speed Setting

The hexacopter has three settings for the responsiveness of the flight controls: 30%, 60%, and 100%. The higher settings allow for faster and more precise control of the craft. It is recommended to start with the lowest setting, then as you become more skilled at flying, increase the sensitivity as you see fit.

- **30%:** Intended for novice pilots. Gives smooth and predictable control.
- **60%:** Intended for intermediate pilots. The hexacopter will move and respond faster to all control inputs.
- **100%:** Intended for expert pilots. Highest setting for maximum performance.

---

## Auto-Return

To enable Auto-Reverse, press down (into the body of the remote) on the **Right Control Stick**. The remote will emit a chime, and the craft will begin flying in the reverse of the direction it was originally flying. Throttle control will still function, but any directional change from the remote will immediately disable this feature.

## Headless Mode

Headless Mode disables the default orientation of the hexacopter, where the white rotors/LEDs indicate the front of the craft. Instead, the craft will reorient its “front” based on the first **Right Control Stick** input from the user. This can be useful if you become disoriented while flying, or cannot visually determine which direction is “true front”.

To activate Headless Mode, press down (into the body of the remote control) on the **Left Control Stick**. Press again to deactivate Headless Mode.

## Flips & Tricks

Before attempting any stunts, be sure that there is ample clear space around the hexacopter, ideally 9 to 10 ft. in every direction. It is not recommended to attempt to stunt around or through any obstacles, as this may result in unintended damage.

**To perform a flip, follow the diagram below.**

Press and hold the Flip button, then move the Right Control Stick in any direction.

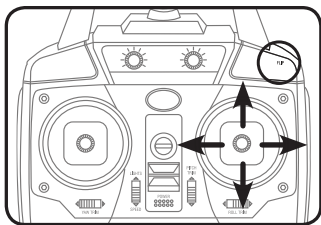

Hexacopter will perform flip in the desired direction.

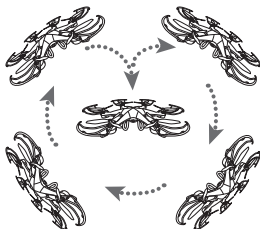

# WiFi Mode

---

## SkyRider Drones App

The hexacopter features a WiFi flight mode that lets you fly using a smartphone and the craft's on board camera. Scan the appropriate QR code below to download and install the free app software. The app can also be found on the Apple App Store or Google Play Store by searching for **SkyRider Drones**.



**IOS/iPhone (Apple)**



**Google Play  
(Android)**

## WiFi Flight

Note that WiFi control may be disabled if the flying area is experiencing interference from nearby 2.4G equipment. It is recommended to move to another area and try again.

### Step 1

Place the hexacopter on a flat, level surface before you begin.

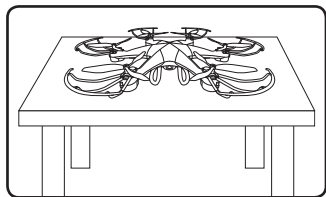

### Step 2

Power the hexacopter ON. The LED formation lights will blink in unison as it awaits a signal from your smartphone.

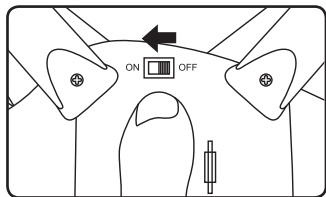

---

## Step 3

Open your phone's WiFi settings and activate WiFi, then search for and select **SkyRider** from the WiFi networks menu.

Once connected, open the app and click on the **Play or Start icons** to begin flying.

When WiFi mode is active, you can save video and images directly to your smartphone.

## Start Screen

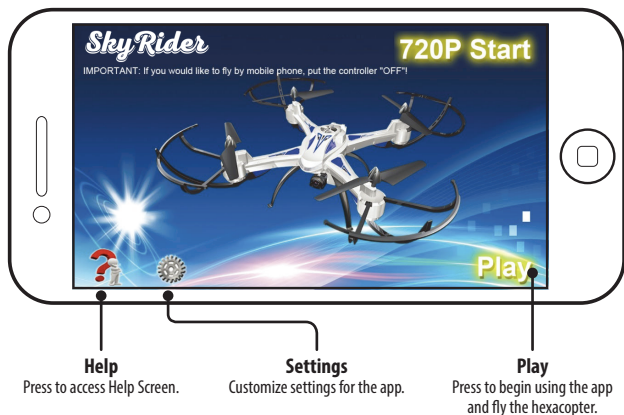

# WiFi Mode

---

## Flight Screen

Note that the airplane and runway graphic (pictured below) is replaced by the view from the hexacopter's on board camera when using the app.

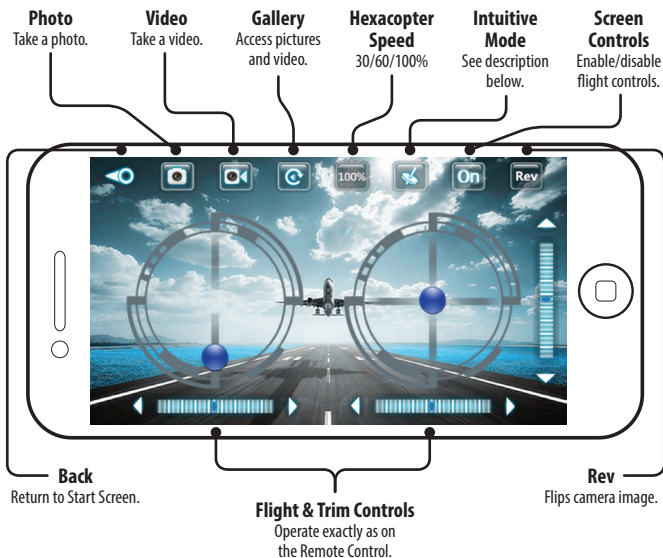

## Intuitive Mode

This mode uses the G-Sensor in a connected smartphone for directional control during flight. Tilt the phone forward, back, left, right, to change the craft's direction. Throttle and yaw control are still manually controlled from the Left Control Stick on the phone's screen.

---

---

## Attaching the Smartphone Cradle

You can use your smartphone and the remote control together by attaching the included smartphone cradle to the top of the remote. This can be useful for photography and video, or for flying the hexacopter just by watching the screen.

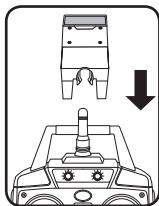

### Step 1

Slide the cradle into position on the remote antenna and handle.

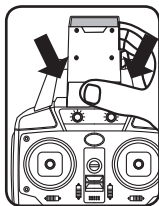

### Step 2

Gently press on the cradle until it locks into place.

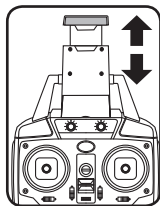

### Step 3

Pull upwards on the top of the cradle so that it will fit your smartphone.

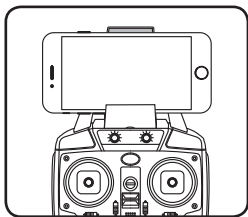

### Step 4

Place your phone in the cradle and release the top portion. Your phone should sit firmly in place.

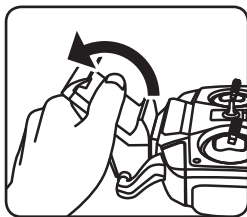

### Removal

Gently pull the cradle off of the remote in a twisting motion, as shown above.

# Factory Reset

---

## Reset Procedure

If for any reason the craft is experiencing difficulty flying or is behaving erratically, and there is no physical damage to any of the mechanical components, the unit may need to be reset to the factory default settings.

### Step 1

Power ON the remote control.

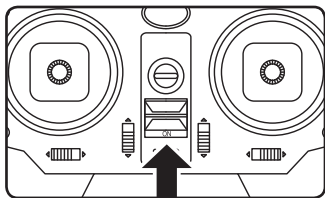

### Step 2

Power on the hexacopter.

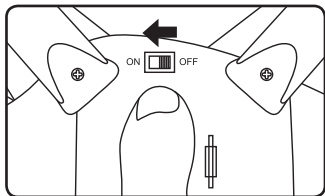

### Step 3

When the LED lights on the hexacopter shift from flashing quickly to flashing slowly, push the throttle all the way forward, wait for a chime to sound, then pull the throttle all the way rearward, and wait for the chime.

The lights on the hexacopter will stop flashing and change to solid.

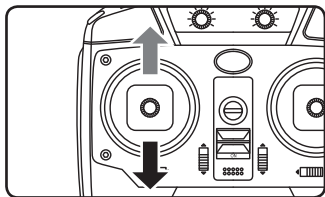

---

## Step 4

Place the hexacopter on a flat horizontal surface, then push both control sticks on the remote all the way down and left, and hold for 2-3 seconds. The lights will begin quickly flashing again. When the lights stop flashing and are solid again, the craft has been reset and is ready to fly.

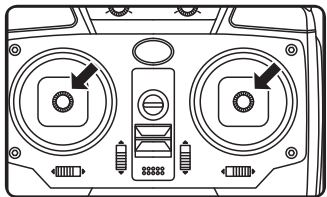

# Repair

---

**REMINDER: Pilots are responsible for any damage caused by improper use.**

## Parts Replacement

Standard parts such as extra batteries and remotes are available online for purchase when in stock. However, any non-standard parts such as cameras, screws, bodies, SD cards etc. can be ordered by placing an inquiry with our parts department at: [partsinfo@dpiinc.com](mailto:partsinfo@dpiinc.com).

## Rotor Replacement

The hexacopter comes with 6 replacement rotors, to be used if the originals are broken or badly damaged.

To replace a rotor, first remove the rotor cap by gently pulling it upwards and off of the rotor. Use a small Phillips head screwdriver (included) and remove the screw connecting the rotor to the electric motor shaft. Remove the damaged rotor and replace it with a new one, then screw it back into place on the motor shaft and replace the rotor cap.

**REMINDER: It is extremely important to use the correct rotor (A or B) for replacement. Using the incorrect rotor will cause the hexacopter's flight to be erratic and impossible to control.**

The marking can be seen on the bottom of the rotor, near the shaft.

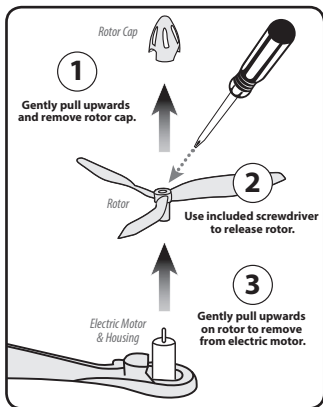

# Troubleshooting

---

If you are experiencing problems using or flying the hexacopter, consult this table.

<b>PROBLEM</b>	<b>POSSIBLE CAUSES</b>	<b>SOLUTION</b>
<b>Hexacopter is unresponsive</b>	<ul style="list-style-type: none"><li>• No power to remote or hexacopter</li><li>• Poor contact between power plugs</li><li>• Hexacopter is out of receiver range</li></ul>	<ul style="list-style-type: none"><li>• Check remote batteries, replace if needed</li><li>• Check hexacopter battery, be sure it is fully charged</li><li>• Be sure the power plugs are firmly connected</li><li>• Be sure the remote has an unobstructed line of sight to the hexacopter</li><li>• Remain within the remote's 250 ft. range</li></ul>
<b>Hexacopter flies erratically</b>	<ul style="list-style-type: none"><li>• Gyroscopes may be misaligned</li></ul>	<ul style="list-style-type: none"><li>• Perform Pre-Flight Calibration again (see pg. 10)</li><li>• Perform factory reset (see pg. 20)</li></ul>
<b>Hexacopter drifts while in flight</b>	<ul style="list-style-type: none"><li>• Trim not set or needs adjustment</li></ul>	<ul style="list-style-type: none"><li>• Adjust trim settings (see pg. 11)</li></ul>
<b>Hexacopter suffers from mechanical difficulty or vibrates excessively</b>	<ul style="list-style-type: none"><li>• Damage to body, rotors, or other major components</li></ul>	<ul style="list-style-type: none"><li>• Check to make sure the hexacopter has not taken significant damage</li><li>• Replacement parts may be needed (see pg. 21)</li></ul>
<b>Formation lights ON, but hexacopter no longer responds to throttle inputs</b>	<ul style="list-style-type: none"><li>• Low battery power</li></ul>	<ul style="list-style-type: none"><li>• Recharge the battery</li></ul>

---

# Company Information

---

## Contact Information

**Website:** [www.gpx.com](http://www.gpx.com)

**Email Support:** [prodinfo@dpiinc.com](mailto:prodinfo@dpiinc.com)

**Email Parts:** [partsinfo@dpiinc.com](mailto:partsinfo@dpiinc.com)

**Phone Support:** 1-888-999-4215

## Warranty

See included 30 Day Warranty for warranty information. Warranty and the most up-to-date version of this User's Guide can also be found at:

**[www.gpx.com](http://www.gpx.com)**

## International Support

To download this User's Guide in English, Spanish, and French, or to get answers to frequently asked questions, visit the support section at: **[www.gpx.com](http://www.gpx.com)**

Para descargar este Manual del Usuario en inglés, español y francés, o para obtener respuestas a preguntas frecuentes, visite la sección de apoyo en: **[www.gpx.com](http://www.gpx.com)**

Pour télécharger ce guide de l'utilisateur en anglais, espagnol ou français, ou pour obtenir des réponses à des questions fréquemment posées, consultez la rubrique d'assistance sur: **[www.gpx.com](http://www.gpx.com)**



Copyright © 2016 Digital Products International (DPI, Inc.) All other trademarks appearing herein are the property of their respective owners. Specifications are subject to change without notice.

---