

Eagle 3 Pro

Quadcopter Drone with Wi-Fi Camera



User's Guide for Model DRW328 v2142-01

Warnings & Precautions

Important Safety Instructions

- Read and follow all instructions.
- Keep these instructions for future reference.
- Heed all Warnings.
- Intended for children ages 14 and higher. Adult supervision is required.
- Only use attachments/accessories specified by the manufacturer.
- Before flying, always check the body, rotors, and battery for any damage or obstructions.
- Battery should be free from cracks or swelling.
- Keep the rotors clear of any obstructions and body parts to avoid potential damage and injury.
- Manufacturer and dealer assume no liability for accidental damages from improper use or installation of parts, or from damage incurred from worn or broken parts.
- Pilots are responsible for their actions and any damage caused from improper use.
- Pilots should keep the craft in sight at all times during flight. If you lose sight of the craft at any time, power down and cease flight immediately.
- Only fly in large, open areas that are free from obstacles or potential hazards, such as trees, power lines, ceiling fans, and the like.
- Flying over bodies of water is not recommended.
- Flying at night is not recommended.
- Never try to retrieve the craft from areas you cannot safely reach, such as rooftops or trees.
- Never launch the craft from your hand.
- Never leave the craft unattended while it is powered on or while the battery is charging.

FCC Warnings

Warning: Changes or modifications to this unit not expressly approved by the party responsible for compliance could void the user's authority to operate the equipment.

NOTE: This equipment has been tested and found to comply with the limits for a Class B digital device, pursuant to Part 15 of the FCC Rules. These limits are designed to provide reasonable protection against harmful interference in a residential installation. This equipment generates, uses, and can radiate radio frequency energy and, if not installed and used in accordance with the instructions, may cause harmful interference to radio communications. However, there is no guarantee that interference will not occur in a particular installation. If this equipment does cause harmful interference to radio or television reception, which can be determined by turning the equipment off and on, the user is encouraged to try to correct the interference by one or more of the following measures:

- Reorient or relocate the receiving antenna.
- Increase the separation between the equipment and receiver.
- Connect the equipment into an outlet on a circuit different from that to which the receiver is connected.
- Consult the dealer or an experienced radio/TV technician for help.

Additional Warnings & Precautions

- **WARNING:** To reduce the risk of fire or electric shock, do not expose this apparatus to rain, moisture, dripping, or splashing.
- **CAUTION:** Use of controls or adjustments or performance of procedures other than those specified may result in personal injury.
- **WARNING:** Changes or modifications to this unit not expressly approved by the party responsible for compliance could void the user's authority to operate the equipment.
- **CAUTION:** Danger of explosion if battery is incorrectly replaced. Replace only with the same or equivalent type.
- Lithium batteries, like all rechargeable batteries, are recyclable and should be recycled or disposed of according to state and local guidelines. They should never be disposed of in normal household waste, and they should never be incinerated, as they might explode. Contact your local government for disposal or recycling practices in your area.
- **WARNING:** Shock hazard - Do Not Open.
- Battery shall not be exposed to excessive heat such as sunshine, fire, or the like.
- Keep new and used batteries away from children. If the battery compartment does not close securely, stop using the product and keep it away from children.
- If you think batteries might have been swallowed or placed inside any part of the body, seek immediate medical attention.
- Do not mix old and new batteries.
- Completely replace all old batteries with new ones.
- Do not mix alkaline, standard (carbon-zinc), or rechargeable (ni-cad, ni-mh, etc) batteries.
- Batteries should be recycled or disposed of as per state and local guidelines.

Table of Contents

Eagle 3 Pro Wi-Fi Drone

FAA Information: Flying Your Drone Under the Special Rule for Model Aircraft – 4

Features – 4

Includes – 4

Diagram & Specifications – 5

Assembly

Rotor Guards – 6

Landing Struts – 6

Camera Adjustment – 6

Remote Control

Functions – 7

Battery Installation – 8

Charging the Battery

Information & Procedure – 9

Flying

Remote Link & Calibration – 10

Flight Controls – 11

When You're Finished Flying – 11

Setting Trim & Countering Drift – 12

Gyroscope Recalibration – 13

Remote Trim Reset – 13

Tips for Safe Operation – 14

Speed Setting – 14

Headless Mode – 14

Auto-Spin – 15

Flips – 15

Sky Rider Flight App

Free Download – 16

Connect to Wi-Fi – 16

Settings Screen – 17

Sky Rider Flight App

Screen Controls – 18

Flight Controls – 19

Virtual Reality Mode – 20

Using the Remote & App Together – 20

3D Mode – 21

Parts & Repair

Parts Replacement – 22

Rotor Replacement – 22

Troubleshooting

Troubleshooting Guide – 23

Customer Support

Contact Information – 24

International Support – 24

Warranty – 24

Eagle 3 Pro Wi-Fi Drone

FAA Information: Flying Your Drone Under the Special Rule for Model Aircraft

To fly under the Special Rule for Model Aircraft you must:

- Fly for hobby or recreation ONLY
- Register your model aircraft
- Fly within visual line-of-sight
- Follow community-based safety guidelines and fly within the programming of a nationwide community-based organization
- Fly a drone under 55 lbs. unless certified by a community-based organization
- Never fly near other aircraft
- Notify the airport and air traffic control tower prior to flying within 5 miles of an airport
- Never fly near emergency response efforts

You alone are responsible for safely and responsibly flying your drone. For more information on FAA Rules and Guidelines for flying Unmanned Aerial Systems please visit: <http://www.faa.gov/uas/>

Features

- 360° flips & tricks
- 6-axis gyroscope
- Free app for Wi-Fi
- Adjustable angle Wi-Fi camera
- 3 speeds
- Control distance: up to 300 feet
- LED navigation lights
- Operating time: 6-8 minutes
- Charge time: approx. 120 minutes

Includes

- USB charging cable
- 2.4GHz remote control: requires 4 AA batteries (not included)
- Rechargeable lithium polymer battery
- 4 Replacement rotors
- 4 Rotor guards and screws
- Detachable smartphone cradle
- Screwdriver
- User's Guide

Diagram & Specifications

- Dimensions: 280x280x107mm/11x11x4.2 in. (LWH)
- Weight: 191g/6.73oz/0.42lb

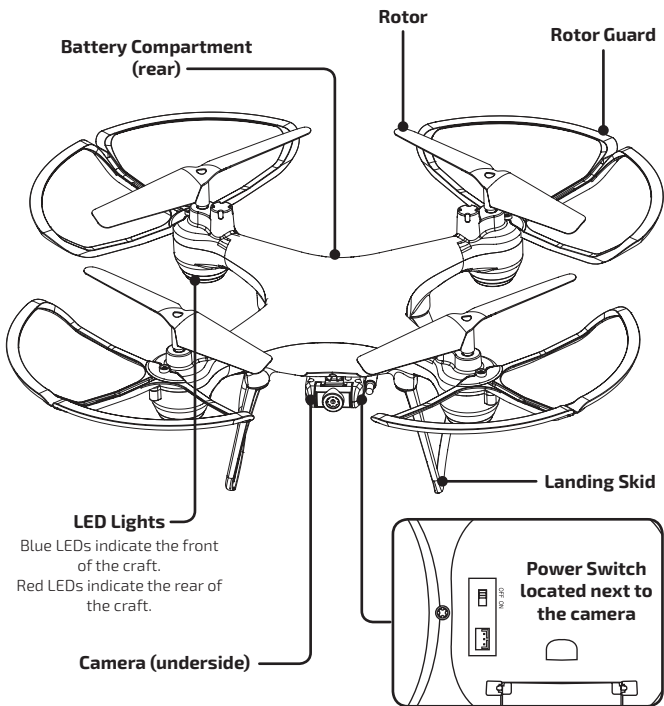

Assembly

Rotor Guards

Attach each rotor guard as shown, then tighten with a screw in the center location using the included screwdriver.

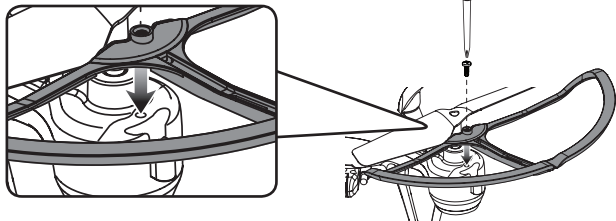

Landing Struts

Place each landing strut on the underside of the craft as shown and press firmly into place.

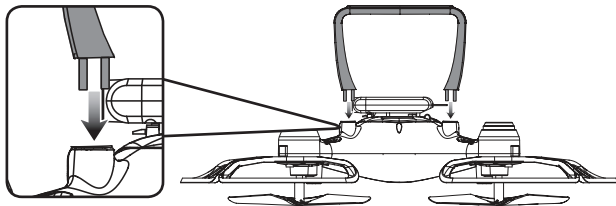

Camera Adjustment

Rotate the camera lens to change the viewing angle.

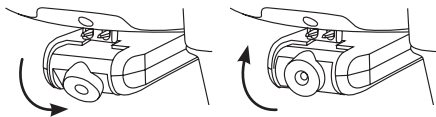

Remote Control

Functions

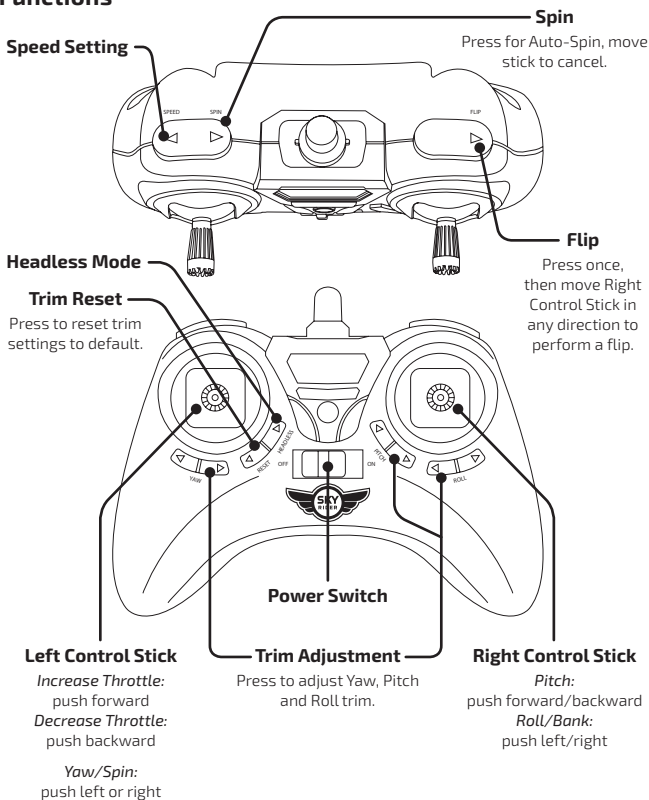

Remote Control

Battery Installation

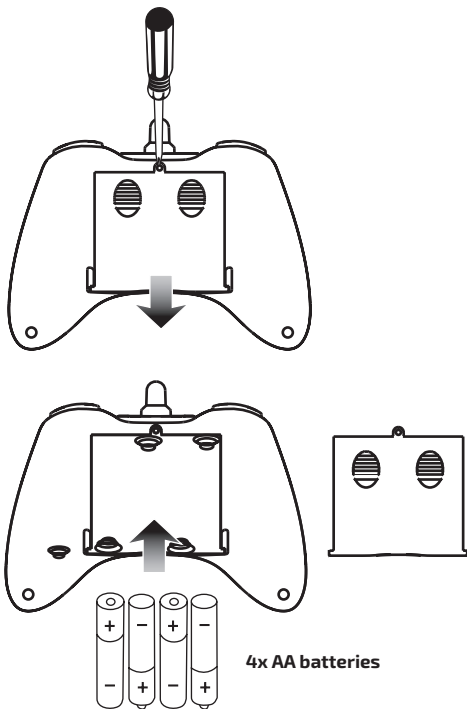

Charging the Battery

Information & Procedure

The craft's battery must be charged before it can be flown. To avoid risk of injury or damage, **be sure the craft and remote control are both powered OFF and remove the battery from the craft when charging.** Charging time is approximately 120 minutes. Charge fully before use for best performance.

Connect the USB charging cable (included) to the USB port of a powered ON computer or USB power adapter (not included), then connect the charging plug to the battery plug.

While charging, the cable will display a red light.

When charging is complete, the light will turn OFF.

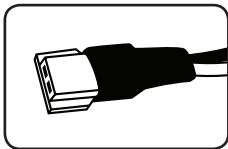
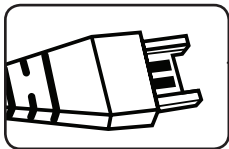
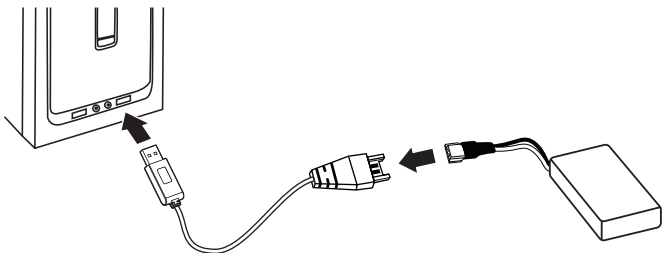

Be sure to correctly match the plug to the charging port or damage may occur.

REMINDER: Do not charge overnight. Do not leave unattended while charging.

Flying

Remote Link & Calibration

Before flying, the craft and the remote must be linked together and the gyroscopes on the craft must be allowed to calibrate.

Begin with the battery installed, the battery compartment closed, and the craft and remote powered OFF.

Step 1

Power ON the craft and place it on a flat surface. This is necessary for the craft's gyroscopes to properly align. The lights on the craft will blink as it searches for a signal from the remote.

Be sure the craft and yourself are facing the same forward direction, this will help with orientation while flying.

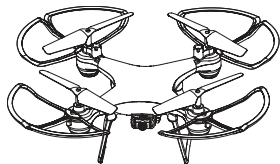

Front

Step 2

Power ON the remote. The light on the remote will blink as it searches for the signal from the craft. An audible chime will sound when the remote and the craft have linked.

Step 3

Push the **Left Control Stick (throttle)** fully forward, wait for a chime to sound, then pull the stick fully rearward, and wait for a second chime. **When this last chime has sounded the craft is ready to fly.**

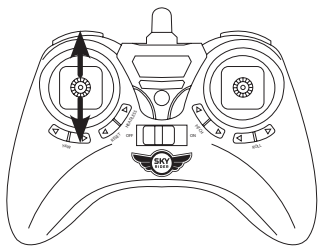

Flight Controls

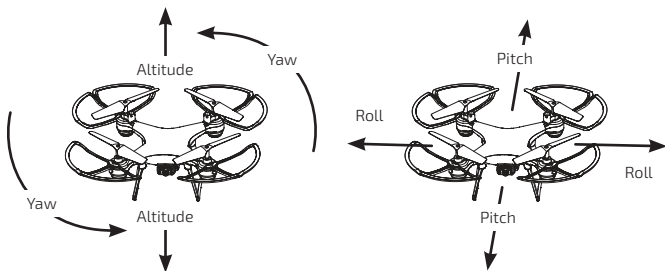

Left Stick controls Altitude (power) and Yaw (spin).

Right Stick controls Pitch (forward/backward) and Roll (left/right).

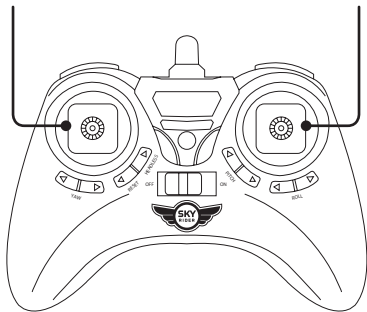

When You're Finished Flying

After landing, keep the Left Control Stick (throttle) in the lowest position and wait for the rotors to stop spinning. **Power OFF the remote BEFORE powering OFF the craft.** This will ensure that no signals are accidentally sent by the remote, reducing the chance of injury. After this is done, it is safe to pick up and power OFF the craft.

Flying

Setting Trim & Countering Drift

Even after the craft is calibrated, it may show a tendency to drift while airborne. Adjusting the trim will help counter this effect and allow better control of the craft.

To avoid potential damage, adjust the trim while attempting a stable hover. Try to avoid making any exaggerated movements with the flight controls and adjust one trim setting at a time to avoid confusion.

Note: Adjusting the trim will help with drift but it will not entirely eliminate it. Air currents and other factors may still cause slight drift while airborne. Adjusting the trim is meant to correct distinct and obvious drift that makes the craft difficult to control.

Craft spins left or right.

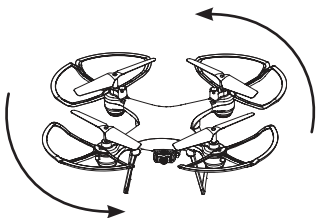

Adjust **Yaw Trim**.

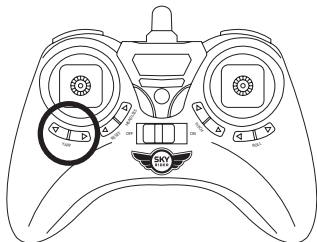

Craft drifts forward or backward.

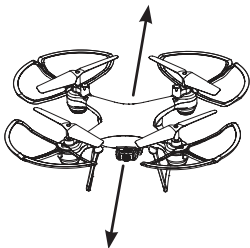

Adjust **Pitch Trim**.

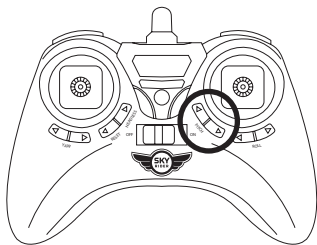

Craft drifts left or right.

Adjust **Roll Trim**.

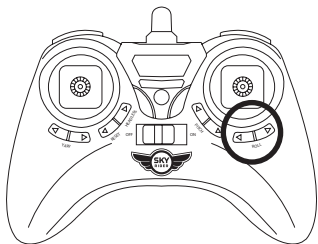
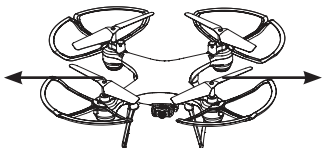

Gyroscope Recalibration

If the craft is having difficulty flying or is behaving erratically, its gyroscopes may need to be recalibrated. Do not attempt to do this while flying, safely land the craft first and place it on a flat surface.

Note: The craft and the remote should already be linked together.

Pull down and to the right on both control sticks for 2-3 seconds. When the LED lights have stopped blinking and turn solid the recalibration is complete and the craft is ready to fly.

Remote Trim Reset

If you are still having difficulty flying, it may help to reset the trim adjustments on the remote. Do not attempt to do this while flying, safely land the craft first.

Press the **Reset** button on the remote. The remote will chime once to indicate that the trim has been reset to default.

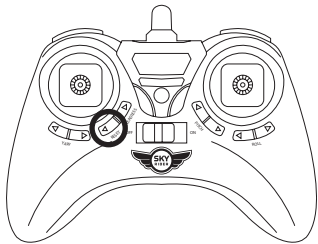
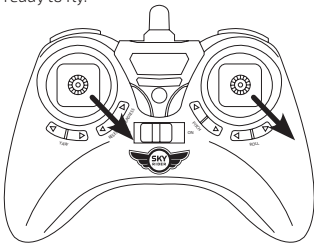

Flying

Tips for Safe Operation

- It is recommended to only fly in large, open spaces that are free of obstacles like power lines, trees, ceiling fans, etc.
- When flying indoors avoid walls and ceilings, as the craft may be drawn towards them if closer than 2-3 feet.
- Stand behind the craft when first taking off, so that you and the craft are facing the same "forward" direction. This will help with orientation when the craft is airborne.
- Novice pilots should move the controls slowly and deliberately to get used to the craft's flying characteristics. Try using one control at a time.
- Practice basic flight operations like take off, hovering, and landing.
- If you get into trouble or if anything obstructs the rotors, cut power immediately and safely clear the obstruction. Check for possible damage before flying again.

Speed Setting

Press the **Speed** button on the remote to change the craft's speed setting.

- **Low:** Provides smooth and predictable control of the craft. The remote will chime once to indicate the low speed setting.
- **Medium:** The craft will move and respond faster to all control inputs. The remote will chime twice to indicate the medium speed setting.
- **High:** Highest setting for maximum performance. The remote will chime three times to indicate the high speed setting.

Headless Mode

Before using Headless Mode be sure you and the craft are facing the same "forward" direction, otherwise the craft will not fly correctly. **To activate Headless Mode, press the Headless button** on the remote control. The LED lights will slowly flash while Headless Mode is ON. Press the button again to deactivate Headless Mode.

While Headless Mode is active the craft will fly in whatever direction the **Right Control Stick** is moved, regardless of where the front of the craft is pointing. For example, if the front of the craft was pointed straight ahead but is now pointed right 90°, when you push forward on the stick the craft will fly forwards as if it was still pointed straight ahead. This can be useful if you become disoriented while flying and cannot visually determine which direction the craft is facing.

Auto-Spin

Press the **Spin** button to activate Auto-Spin. The craft will spin (yaw) in a clockwise direction. Press the **Spin** button again or move the **Right Control Stick** in any direction to cancel Auto-Spin.

Use the **Left Control Stick** to control the altitude of the craft while in Auto-Spin.

Flips

Before attempting a flip, be sure that there is ample clear space around the craft, ideally 9-10 ft. in all directions. It is not recommended to attempt to flip around or through any obstacles, as this may result in unintended damage.

Press the **Flip button** to activate Flip Mode, then move the Right Control Stick in any direction and the craft will perform a flip in the same direction. Press the **Flip button** again to deactivate without performing a flip.

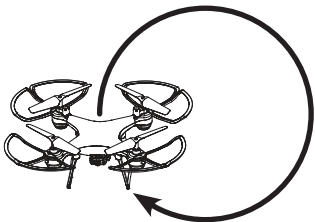
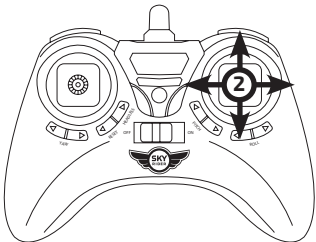
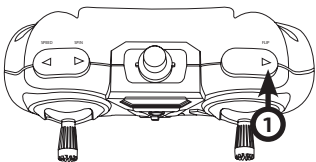

Sky Rider Flight App



The Sky Rider Flight app will display the image from the craft's camera on your smartphone's screen, allowing you to capture images and video of your flights. Connect your smartphone to the craft's Wi-Fi signal and start flying!

Free Download

Scan the appropriate QR code with your smartphone or search for "**Sky Rider Flight**" in the Apple App Store or Google Play Store.



Android

Connect to Wi-Fi

NOTE: Wi-Fi control may be interrupted by interference from other nearby Wi-Fi equipment.

Before beginning, make sure your phone's Wi-Fi is enabled and the craft is powered ON.

- From your smartphone, open the Wi-Fi settings menu, then search for and select **Sky Rider Command_xxx** to connect to the craft.
- Once connected, open the app. You will see the **Home Screen** (image below). From here you can adjust settings and start using the app.



Apple



1. Help

2. App Settings

3. Start App

Settings Screen

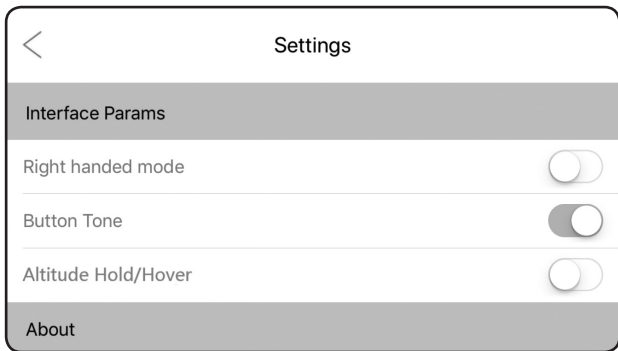

Flight Parameters

Auto Save Parameters - Trim settings adjusted in the app will be saved for future flights. *Be sure to reset the parameters before flying a different craft with the app.*

Reset Fine Tune Parameters - Reset trim settings to default.

Interface Parameters

Right Hand Mode - Reverses the locations of the Left and Right flight controls on the screen.

Button Tone - Buttons will chime when pressed.

Altitude Hold/Hover - Enables Altitude Hold/Hover controls for the app. Not all Sky Rider drones are equipped for Altitude Hold,

if your craft does not have this feature, do not enable this setting.

About

Software Version - Displays software version number.

Sky Rider Flight App

Screen Controls

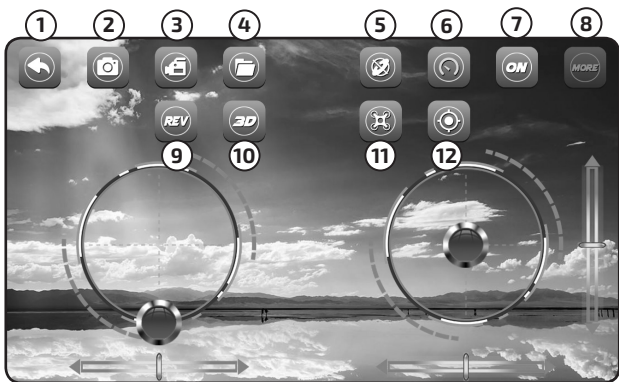

- | | | |
|------------------------|---|-----------------------|
| 1. Back to Home Screen | 6. Speed Setting | 10. 3D View (VR Mode) |
| 2. Take Photo | 7. Flight Controls ON/OFF | 11. Headless Mode |
| 3. Record Video | 8. More Controls
(displays 9-12 below) | 12. Gyro Calibration |
| 4. Photo/Video Gallery | 9. Flip Camera View 180° | |
| 5. Intuitive Mode | | |

Intuitive Mode uses the G-Sensor in your phone to control the craft. Tilt the phone forward, back, left and right to control the **pitch and roll** of the craft. **Throttle and yaw** are still manually controlled from the **Left Directional Control**.

Camera & Video

Use the **Photo and Video buttons** to document your flight. Images and video are saved to your phone and can be viewed later by pressing the **Gallery button**.

Flight Controls



1. Throttle/Yaw Control
2. Pitch/Roll Control
3. Yaw Trim (tap arrow once to adjust)
4. Roll Trim (tap arrow once to adjust)
5. Pitch Trim (tap arrow once to adjust)

Sky Rider View App

Using the Remote & App Together

It can be easier to capture photos and video by using the remote to fly the drone and using the app in a viewing only method. Use the app and the remote together by attaching the smartphone holder (included) to the remote and placing your phone in the holder.

Follow the steps below to connect to the remote and the app in the proper sequence.

- **First, connect the remote to the craft like normal.** Connecting the remote first overrides any control signals from the app.
- Next, use your phone to connect to the craft's Wi-Fi. Open the app and go to the Flight Screen. Leave the Flight Controls off for the best view from the drone's camera.
- **Use the controls on the remote** to fly the craft while the Wi-Fi camera streams to your phone.
- When you're finished flying, power down the remote and craft like normal.

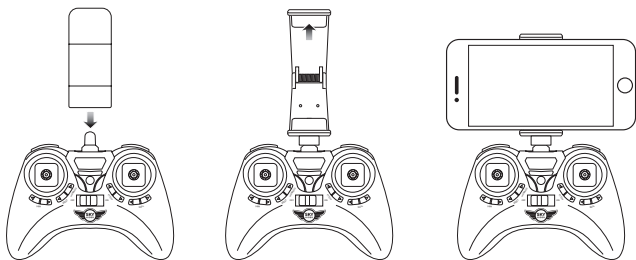

3D Mode

VR Mode splits the phone's screen for use in a VR headset. **Press the 3D button** on the screen to turn this feature ON or OFF. Use VR Mode to give a friend a fully immersive, point-of-view flying adventure.

NOTE:

- On screen flight controls are locked out in VR Mode. You must have the regular remote connected in order to fly the craft.
- **We do not recommend flying the craft while wearing a headset.** The craft's camera has a limited forward view and the headset will completely obscure the user's peripheral vision and situational awareness. **Pilots assume all risk and are responsible for any damage caused by improper use.**

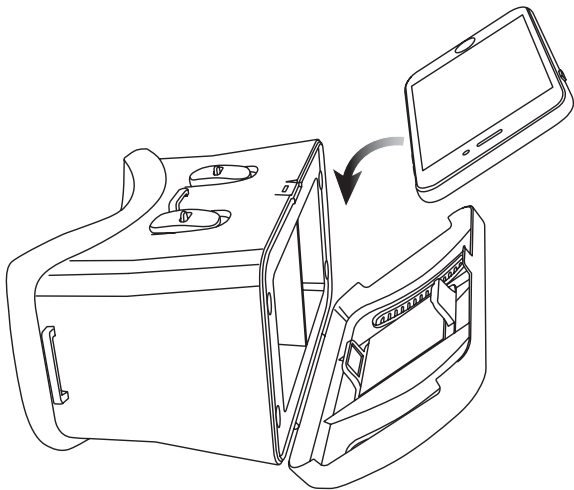

Parts & Repair

REMINDER: Pilots are responsible for any damage caused by improper use.

Parts Replacement

Standard parts such as extra batteries and remotes are available online for purchase when in stock. However, any non-standard parts such as cameras, screws, bodies, etc. can be ordered by placing an inquiry with our parts department at: partsinfo@dpiinc.com.

Rotor Replacement

The craft comes with replacement rotors if the originals are broken or badly damaged. Use the included screwdriver to remove the rotor retaining screw that holds the rotor to the motor shaft. Once the retaining screw is out, pull upwards on the rotor to remove it from the motor shaft. Installation of the new rotor is the reverse of the removal process. Be sure to tighten the rotor retaining screw firmly, but do not over tighten.

It is extremely important to use the correct rotor (A or B) for replacement. Using the incorrect rotor will make the craft impossible to control. The marking can be found on the rotor near the shaft.

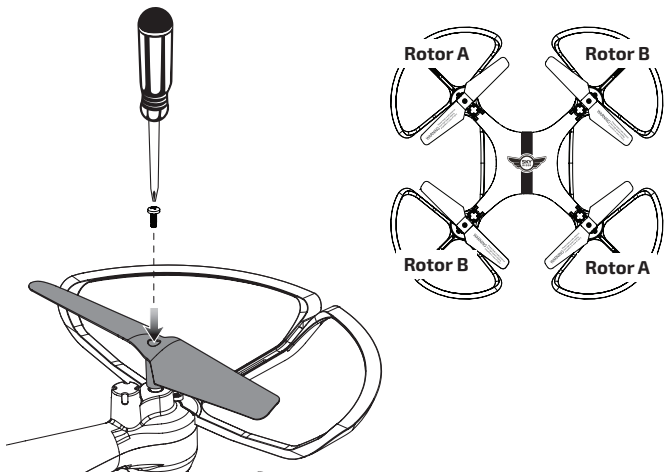

Troubleshooting

Troubleshooting Guide

PROBLEM	POSSIBLE CAUSES	SOLUTION
Craft does not respond to controls.	<ul style="list-style-type: none">• No power to remote or craft.• Poor contact between power plugs.• Craft is out of range.	<ul style="list-style-type: none">• Check remote batteries, replace if needed.• Check craft battery, be sure it is fully charged.• Be sure the power plugs are firmly connected.• Be sure the remote has an unobstructed line of sight to the craft.• Remain within the remote's 300 ft. range.
Craft is difficult to control or flies erratically.	<ul style="list-style-type: none">• Gyroscopes may be misaligned.	<ul style="list-style-type: none">• Power OFF remote and craft and reconnect (see pg. 10).
Craft drifts while in flight.	<ul style="list-style-type: none">• Trim not set or needs adjustment.	<ul style="list-style-type: none">• Adjust trim settings (see pg. 12).
Craft suffers from mechanical trouble.	<ul style="list-style-type: none">• Damage to body, rotors or other major components.	<ul style="list-style-type: none">• Repair or replace parts as needed.
LED lights ON but craft does not respond to controls.	<ul style="list-style-type: none">• Low battery power.	<ul style="list-style-type: none">• Recharge the battery.

Customer Support

Contact Information

Website: www.gpx.com

Email Support: prodinfo@dpiinc.com

Email Parts: partsinfo@dpiinc.com

Phone Support: **1-888-999-4215**

Warranty

See included 30 Day Warranty for warranty information. Warranty and the most up-to-date version of this User's Guide can also be found at: www.gpx.com

International Support

To download this User's Guide in English, Spanish, and French, or to get answers to frequently asked questions, visit the support section at: www.gpx.com

Para descargar este Manual del Usuario en inglés, español y francés, o para obtener respuestas a preguntas frecuentes, visite la sección de apoyo en: www.gpx.com

Pour télécharger ce guide de l'utilisateur en anglais, espagnol ou français, ou pour obtenir des réponses à des questions fréquemment posées, consultez la rubrique d'assistance sur: www.gpx.com



***Protect for Today
Sustain for Tomorrow***

Copyright © 2018 Digital Products International (DPI, Inc.) All other trademarks appearing herein are the property of their respective owners. Specifications are subject to change without notice.